

P70
TiN

P70
TiH1

P70 6GX
TiH1

P70 7GX
TiH1

DIN 371
≤ M10

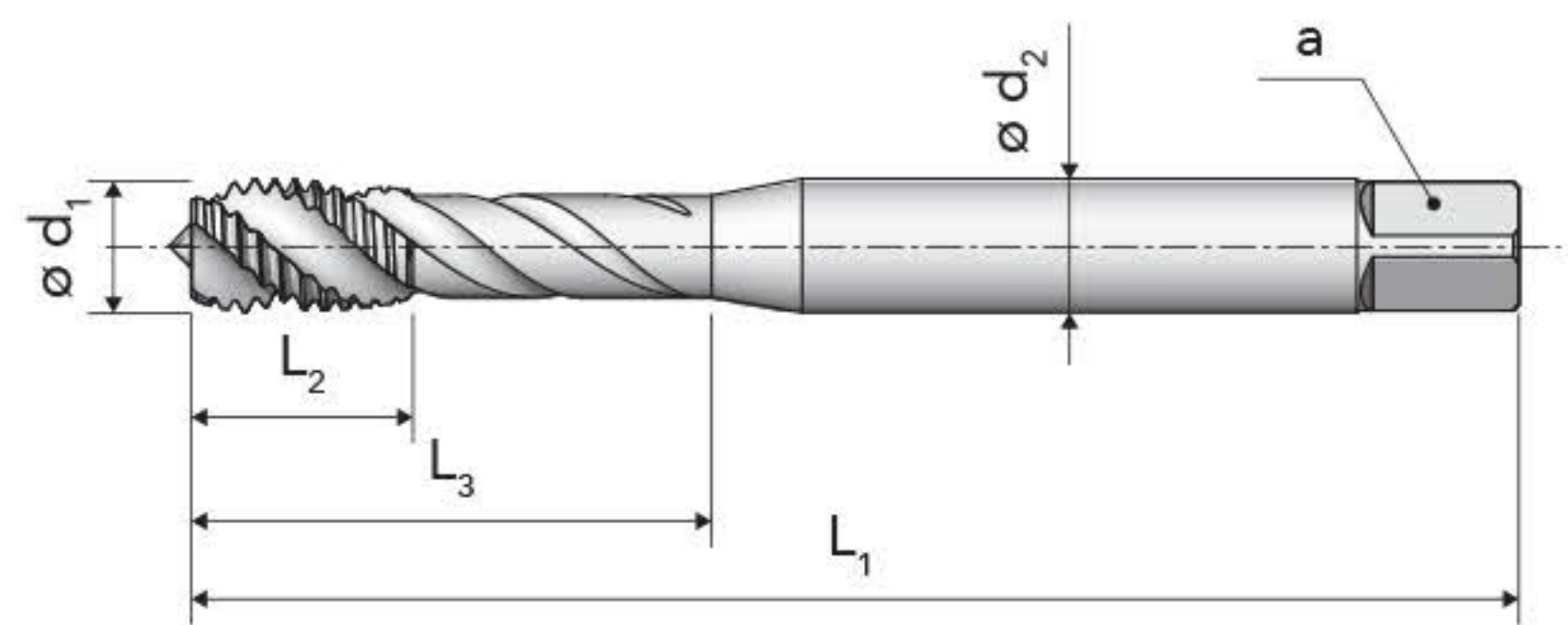

DIN 376
≥ M12

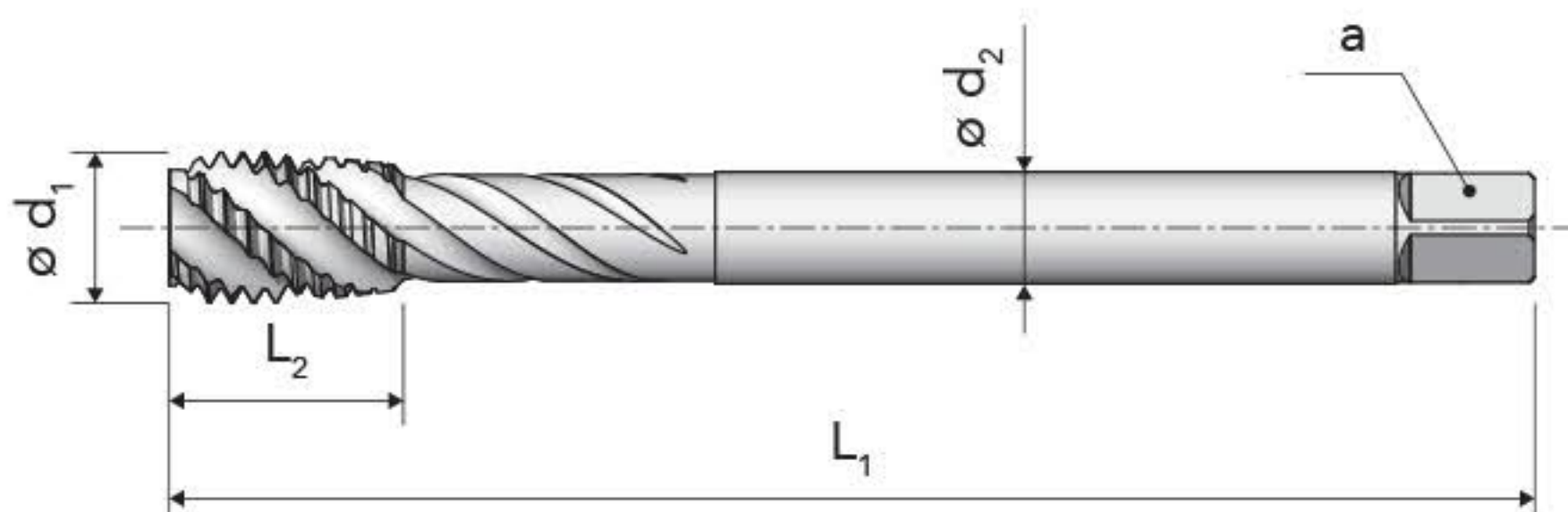

CAMPO D'IMPIEGO - VELOCITÀ DI TAGLIO m/min

ISO	MG	P70 TiN	P70 TiH1	P70 6GX TiH1	P70 7GX TiH1
P	P.3	● 20-30	● 20-30	● 20-30	● 20-30
	P.4	● 15-25	● 15-25	● 15-25	● 15-25
	P.5	● 5-15	● 5-15	● 5-15	● 5-15
	P.7	● 10-15	● 10-15	● 10-15	● 10-15
M	M.1	● 10-15	● 10-15	● 10-15	● 10-15
	M.2	● 5-7	● 5-7	● 5-7	● 5-7
K	K.2	● 20-30	● 20-30	● 20-30	● 20-30
N	N.3	● 25-35	● 25-35	● 25-35	● 25-35
	N.6	● 25-35	● 25-35	● 25-35	● 25-35
S	S.1		● 10-15	● 10-15	● 10-15
	S.3	● 10-15	● 10-15	● 10-15	● 10-15

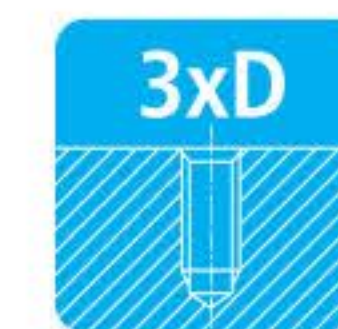

Ød ₁	P	L ₁ js 16	L ₂	L ₃	Ød ₂ h9	a h12	z		P70 TiN	P70 TiH1	P70 6GX TiH1	P70 7GX TiH1
[mm]	[mm]	[mm]	[mm]	[mm]	[mm]	[mm]	[-]	[mm]	A...0704A1AD0	A...0704A1AH0	A...0704A1CH0	A...0704A1DH0
M 2	0,4	45	6	12	2,8	2,1	3	1,6	...00020...	...00020...		
2,5	0,45	50	6,5	15	2,8	2,1	3	2,05	...00025...	...00025...		
3	0,5	56	7	15	3,5	2,7	3	2,5	...00030...	...00030...	...00030...	...00030...
4	0,7	63	8,5	21	4,5	3,4	3	3,3	...00040...	...00040...	...00040...	...00040...
5	0,8	70	10	24,5	6	4,9	3	4,2	...00050...	...00050...	...00050...	...00050...
6	1	80	12	29	6	4,9	3	5	...00060...	...00060...	...00060...	...00060...
8	1,25	90	14	33	8	6,2	3	6,8	...00080...	...00080...	...00080...	...00080...
10	1,5	100	17	39	10	8	3	8,5	...00100...	...00100...	...00100...	...00100...
12	1,75	110	18	-	9	7	4	10,2	...00120...	...00120...	...00120...	...00120...
14	2	110	20,5	-	11	9	4	12	...00140...	...00140...	...00140...	
16	2	110	20,5	-	12	9	4	14	...00160...	...00160...	...00160...	
18	2,5	125	25,5	-	14	11	4	15,5	...00180...	...00180...	...00180...	
20	2,5	140	25,5	-	16	12	4	17,5	...00200...	...00200...	...00200...	
24	3	160	32	-	18	14,5	4	21	...00240...	...00240...		
27	3	160	32	-	20	16	5	24	...00270...	...00270...		
30	3,5	180	37	-	22	18	5	26,5	...00300...	...00300...		
33	3,5	180	37	-	25	20	5	29,5	...00330...	...00330...		
36	4	200	42	-	28	22	5	32	...00360...	...00360...		
42	4,5	200	45	-	32	24	5	37,5	...00420...	...00420...		